

⑫

EUROPEAN PATENT APPLICATION

published in accordance with Art. 158(3) EPC

⑰ Application number: 84901016.0

⑮ Int. Cl.⁴: **G 01 N 27/30**
G 01 N 27/46

⑱ Date of filing: 06.03.84

Data of the international application taken as a basis:

⑲ International application number:
PCT/JP84/00087

⑳ International publication number:
WO84/03562 (13.09.84 84:22)

⑳ Priority: 11.03.83 JP 40885/83
19.07.83 JP 132403/83

⑴ Applicant: **Matsushita Electric Industrial Co., Ltd.**
1006, Oaza Kadoma
Kadoma-shi Osaka-fu, 571(JP)

㉑ Date of publication of application:
10.04.85 Bulletin 85/15

⑵ Inventor: **KAWAGURI, Mariko**
19-8, Senrioka-kami Suita-shi
Osaka-fu 565(JP)

㉒ Designated Contracting States:
DE FR GB

⑶ Inventor: **NANKAI, Shiro**
50-12, Nasuzukuri 4-chome Hirakata-shi
Osaka-fu 573(JP)

⑷ Inventor: **IJIMA, Takashi**
35-26, Yamanoue-nishimachi Hirakata-shi
Osaka-fu 573(JP)

⑸ Representative: **Eisenführ & Spelser**
Martinistrasse 24
D-2800 Bremen 1(DE)

⑸ **BIOSENSOR.**

⑸ A measuring electrode (27) and an adjacent electrode (28) are embedded in an insulating substrate (26). The exposed surface of the electrode system is coated with a porous substance (29) carrying an oxidation reductase (30) and, if needed, an electron acceptor (31) in a dry state, to form a biosensor. A predetermined voltage is applied between the electrodes (27, 28) of the biosensor, and a matrix-containing sample is dropped on the porous substance (29). A current proportional to the substrate concentration flows, so it is possible to quantitatively determine the matrix concentration of various biological samples highly accurately, rapidly and easily.

FIG. 7

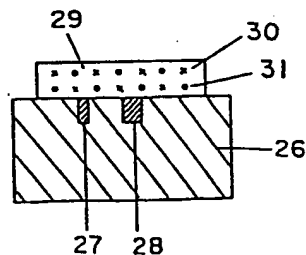

0136362

SPECIFICATION

TITLE MODIFIED

front page

Title of the Invention:

A BIO-SENSOR

Technical Field:

The present invention relates to a bio-sensor which makes it possible to determine the particular component of various biological samples with ease, rapidity and high precision.

Background of the invention:

In recent years, various kinds of bio-sensor based on the specific catalytic action of enzyme have been developed, and particularly, their application to clinical inspection field is being tried. At the present day wherein inspection items and the number of specimens are increasing, bio-sensors which enable rapid and high-precision measurement are demanded.

A case of glucose sensor will be taken as example. In these days of remarkable increase of diabetes, for measurement and control of blood sugar in blood, there is a demand for sensors applicable to tests on whole blood, because it takes a very long time to centrifuge blood and measure the separated plasma as conventionally carried out. a simple sensor is available. Like the test paper used for

urinalysis, this sensor comprises a stick-form support and a carrier put on the support containing an enzyme which will react with glucose only and a dye which will change itself on enzyme reaction or by the product of the reaction. Blood is added to the carrier, and a change in the dye after a definite period of time is measured visually or optically. But, the measurement is largely disturbed by dyes in blood, so that its precision is low.

The multi-layer analytical carrier was thus proposed as shown in Fig. 1 (Japanese Utility Model Opening (KOKAI) No. 178495/1979). This carrier has a laminated structure wherein a reagent layer 2, developing layer 3, water-proof layer 4 and filter layer 5 are placed one upon another in this order on a transparent support 1. When a blood sample is dropped down to the carrier, the blood is first freed from its solid components such as red blood cells, blood platelets, etc. on the filter layer 5, uniformly diffuses into the developing layer 3 through small pores in the water-proof layer 4 and comes into reaction in the reagent layer 2. After completion of the reaction, light is passed through the transparent support in the direction of an arrow to measure the substrate concentration spectroanalytically. Although this carrier is complicated in structure as compared with the conventional sample stick-form carrier, an improvement in precision was attained by removing blood cells, etc. But, it takes a long time for

0136362

the penetration and reaction of blood, so that there was a necessity to put the water-proof layer 4 for preventing the sample from drying and to incubate at high temperatures for accelerating the reaction, which caused a problem of the apparatus and carrier becoming complicated.

Thus, an electrode method comprising combining enzyme reaction with electrode reaction was developed as a simple method of good precision. Since there is no disturbance of colored substances in the electrode method, the liquid sample can be used as it is without a necessity for pre-treatment, and therefore, the measurement became simple and precision was also improved. A case of glucose sensor will be taken as example. A flow-type sensor was developed as shown in Fig. 2 in which a liquid sample, e.g. blood or urine, is added to the sensor while applying a definite voltage to a glucose oxidase immobilized electrode 6 and passing a buffer solution 7 through a conduit 8 made of insulating materials such as acrylic resin; glucose in the sample reacts with the immobilized glucose oxidase to produce hydrogen peroxide which is then oxidized at the electrode 6 to generate a current; and the glucose concentration of the sample can be detected by measuring the strength of the current. The sensor of this type enables as many specimens as 200 to 300 per hour to be measured with rapidity and high precision, but it had a problem that the apparatus becomes large in size. The so-called batch-type

0136362

sensor as shown in Fig. 3 was thus developed in which a glucose oxidase immobilized electrode 11 is placed in a vessel 10 which is then filled with a buffer solution 12, and a liquid sample is added to the solution while stirring with a stirrer. The size of apparatus could be made fairly small by using this type, but there occurred problems that a stirrer is essential, and that foaming and turbulent flow are caused by stirring to exert an adverse effect on the precision. Also, there was a necessity to exchange the buffer solution and sometimes wash the electrode, and besides, because of the liquid sample being diluted with the buffer solution, precision was required for the amounts of buffer solution and liquid sample.

Thus, for simple measurement, a dry measurement-form sensor requiring no stirring apparatus is demanded, and besides a high precision is required.

Disclosure of the invention:

The bio-sensor of the present invention is composed of an insulating substrate plate and an electrode system comprising a working electrode and a counter electrode put thereon, said system being covered with a porous substrate comprising at least one layer containing oxidoreductase. This sensor is intended to measure the concentration of substrates, e.g. urine sugar and blood sugar, by electrochemically detecting a reduced electron

0136362

acceptor produced when it is impregnated with a liquid sample to carry out enzyme reaction, and also it is intended to measure the glucose concentration of fruit juices.

By using the bio-sensor of the present invention, measurement can be carried out by merely adding a liquid sample directly to the porous substrate containing at least enzyme without using a buffer solution. Also, since the sample need not be diluted, there is no necessity to determine the sample and besides a trace amount of the particular component of the sample can be measured with simplicity and high sensitivity.

Brief explanation of the drawing:

Fig. 1 is a typical view illustrating one embodiment of the conventionally used glucose sensors. Figs. 2 and 3 are typical views illustrating the conventional glucose sensor using an immobilized enzyme electrode. Fig. 4 is a typical view illustrating one embodiment of the bio-sensor of the present invention. Figs. 5 and 6 show the response characteristics of the bio-sensor shown in Fig. 4. Figs. 7, 8 and 9 are typical views illustrating other embodiments of the bio-sensor of the present invention.

Best form for practice of the invention:

Example 1

Explanation will be given on a glucose sensor which is one of bio-sensors. Glucose oxidase was used as oxidoreductase, and potassium ferricyanide was used as an oxidizing dye working in conjugation with the oxidoreductase. Fig. 4 is a typical view illustrating one embodiment of a glucose sensor. Pieces of platinum wire of 1mm in diameter were buried in an insulating substrate plate 19 made of a polyvinyl chloride resin to prepare a working electrode 20, counter electrode 21 and reference electrode 22, and nylon non-woven fabric 23 was put on the foregoing electrode system so as to cover the system. This nylon non-woven fabric 23 was prepared as follows: 100mg of glucose oxidase and 150mg of potassium ferricyanide are dissolved in 1 c.c. of a phosphate buffer solution (pH 5.6), and nylon non-woven fabric is impregnated with the solution thus prepared and dried at room temperature.

A standard glucose solution, a liquid sample, was added to the nylon non-woven fabric 23 and after allowing the solution to well penetrate into the fabric, voltage was applied to the working electrode 20 with the reference electrode 22 as standard and varied at a rate of 0.1 V/sec so that it drew a saw-toothed line between 0 V and +0.5 V. When the added glucose is oxidized by glucose oxidase 24 carried on the nylon non-woven fabric 23, potassium ferricyanide 25 is reduced by enzyme/dye conjugation reaction to produce potassium ferrocyanide. On oxidizing

the potassium ferrocyanide by sweeping voltage applied to the working electrode 20, anodic current flows. This anodic current is directly proportional to the amount of dye changed, and when the dye is present in sufficient amounts, since said amount corresponds to the substrate concentration, the concentration of glucose, a substrate, can be detected by measuring the strength of the anodic current. The relationship between the strength of peak current obtained and the concentration of glucose added showed a very good rectilinearity in the range of up to 500mg/dl as shown by A in Fig. 5. The nylon non-woven fabric 23 was exchanged at every measurement, but reproducibility was good. Also, the amount of the standard glucose solution added was varied from 20 μ l to 140 μ l, but a definite value was obtained independently of the amount of the solution as shown by C and D in Fig. 6 when the glucose concentration was definite.

Example 2

The electrode system used in Example 1 was covered at the upper surface with nylon non-woven fabric carrying glucose oxidase only, and then measurement was carried out in the same manner as in Example 1 with dropwise addition of the standard glucose solution. In this system, oxygen contained in air and the liquid sample is used as the electron acceptor; when glucose reacts with glucose oxidase, hydrogen peroxide is produced in an amount corresponding to

the glucose concentration and oxidized at the surface of the electrode; and the strength of anodic current generated by the oxidation is measured to obtain the glucose concentration. The peak of the current obtained, as shown by B in Fig. 5, showed a rectilinear rise up to 300mg/dl but little or no rise at higher concentrations than this. The reason for this may be considered to be due to that supply of oxygen is not sufficient when the substrate concentration is high. But, measurement was possible at low concentrations of the substrate.

Example 3

Fig. 7 is a typical view illustrating another embodiment of the glucose sensor of the present invention. As shown in Example 1, measurement can stably be carried out if a three-electrode system comprising a working electrode, a counter electrode and a reference electrode is used, but it can also be carried out with a two-electrode system comprising a working electrode and a counter electrode. Platinum was buried in an insulating substrate plate 26 made of a polyvinyl chloride resin to prepare a working electrode 27 and counter electrode 28. To stabilize the potential, the area of the counter electrode 28 was made at least more than two times as large as that of the working electrode 27. In the same manner as in Example 1, this electrode system was covered at the upper surface with nylon non-woven fabric 29 carrying glucose oxidase 30 and potassium ferricyanide

0136362

31, and measurement was carried out with dropwise addition of the standard glucose solution. It was found that the reproducibility was slightly poorer than in Example 1, but that glucose concentrations of up to 500mg/dl could be measured. A silver/silver chloride (Ag/AgCl) counter electrode was used in place of the platinum one 28, and it was found that the potential was stabilized, and that measurement could be carried out with good reproducibility if the area of this electrode was made equal to that of the electrode 27.

Example 4

Fig. 8 is a sensor comprising an insulating substrate plate 32 made of a polyvinyl chloride resin and a working electrode 33, counter electrode 34 and reference electrode 35 in a thin film form which were produced from platinum on the substrate plate by the sputtering method. On these electrodes was placed the same nylon non-woven fabric carrying the enzyme and oxidizing dye as used in Example 1 so as to cover the region shown by a dotted line. Thereafter, response to the standard glucose solution was measured in the same manner as in Example 1 to obtain the same good response as in the electrode system in Fig. 4. Next, measurement was repeated using the standard glucose solution of the same concentration as well as the electrodes and nylon non-woven fabric newly exchanged at every measurement, and as a result, a very good reproducibility

0136362

was obtained. Consequently, if the electrodes are produced by the sputtering method or vacuum deposition method as in this example, electrodes having the same response characteristics and any desired shape can be produced in large amounts, and by covering the electrodes with a porous substrate carrying enzyme and oxidizing dye, high-performance bio-sensors which can be disposed after use, can be provided.

Example 5

Fig. 9 is a typical view illustrating one embodiment of a glucose sensor. Platinum is buried in an insulating substrate plate 36 made of a polyvinyl chloride resin to prepare a working electrode 37, counter electrode 38 and reference electrode 43. Nylon non-woven fabric 39 is placed on the electrode system comprising these electrodes so as to cover the system. This nylon non-woven fabric 39 is a one prepared through the same dissolution, impregnation and drying as in Example 1, and it carries glucose oxidase 40 (oxidoreductase) and potassium ferricyanide 41 (oxidizing dye), which works in conjugation with oxidoreductase, in a dry form. On the upper surface of the fabric 39 is placed a filter layer 42 comprising porous polycarbonate (pore diameter, 1 μ m).

On adding blood (whole blood) to this sensor, large molecules in blood such as red blood cells were filtered off on the filter layer 42, and glucose in the

0136362

blood came into reaction at the reaction layer comprising the nylon non-woven fabric 39 in the same manner as in Example 1, whereby the glucose concentration could be detected at the electrode system. That is, from the strength of a current obtained, the glucose concentration could be detected based on a calibration curve previously prepared with a standard glucose solution. The current strength and glucose concentration showed a good correlation as compared with the conventionally used types of glucose sensor. The reaction layer comprising the enzyme and oxidizing dye and the filter layer were exchanged at every measurement, but the reproducibility was good in either sample of standard glucose solution and blood. Also, the amount of blood added was varied from 20 μ l to 140 μ l, but the amount of glucose showed a definite value independently of said amount since the dye and enzyme were present in sufficient amounts.

By using the porous substrate of polycarbonate as the filter layer 42, blood cells and viscous substances present in blood could previously be removed, and as a result, stains on the electrode could be decreased. Without the filter layer, blood cells adhered to the electrode during a long-term use to lower the strength of current obtained, so that there was necessity to wash the electrode with alcohol. But, by using the filter layer, it became possible to maintain the response with good reproducibility

0136362

by merely washing the electrode with water. Also, it was found that the porous substrate which was useful to the above object was a one having a pore diameter within about 3 μ m. Further when the porous substrate of polycarbonate was used after dipped in a 1% aqueous solution of surface active agent, e.g. polyethylene glycol alkylphenyl ether (trade name: Triton X) and dried, filtration of blood became very fast with a further improved reproducibility. Hitherto, there was a problem that, since blood is fairly viscous, its filtration rate is low. But, by using a filter layer previously treated with surface active agents, filtration became fast and also reaction with enzyme and dye proceeded rapidly and uniformly to come to an end in as short a time as only about one minute after addition of a test sample. When the surface active agent was not used, it took about 1.5 minutes for the reaction to come to an end after addition of blood, and therefore the effect of the surface active agent to accelerate the measurement was large.

As the surface active agent, polyoxyethylene glycerin fatty acid esters, polyoxyethylene alkyl ethers, polyethylene glycol fatty acid esters and the like can be used in addition to the foregoing example. By previous treatment of not only the filter layer but also the dye and enzyme with the surface active agent, the rates of filtration and penetration became fast to make it possible to accelerate the measurement.

0136362

The reaction layer comprising the oxidizing dye and enzyme is preferably a hydrophilic porous membrane so that it can absorb the liquid sample rapidly to advance the enzyme reaction. For example, when filter paper, non-woven fabric of pulp, porous substrate of ceramic or glass, etc. were used in addition to the nylon non-woven fabric, penetration of the liquid sample was quick and uniform, and reproducibility was also good. Further, the rate of penetration of the sample into the above porous membrane was larger in the membrane pre-treated with the foregoing surface active agent than in the untreated membrane. The filter layer having an effect to accelerate the measurement may be placed on the electrode or the upper surface of the reaction layer. Penetration of the liquid sample was fastest when the filter layer was placed below the reaction layer, and the reaction time was also short. While, when the filter layer was placed on the reaction layer, there was an advantage that the reaction proceeds smoothly and a high precision is obtained because the solid component of blood can first be filtered off so that there is no disturbance of blood cells, etc. in the reaction layer. For the filter layer, use of non-woven fabrics, chemical fibers, paper (filter paper), etc. was thought of. But, the material component of blood cells could completely be filtered off by using membrane filter having a pore diameter of less than about 2-3 μm . Also, filtration could be carried out

0136362

stepwise by laminating the membrane filter layer with the foregoing non-woven fabric, chemical fiber, paper or the like.

In the above sensor, various methods could be employed to carry glucose oxidase (enzyme) and potassium ferricyanide (dye). For example, it was also possible to laminate two pieces of nylon non-woven fabric carrying the enzyme and dye, respectively. In carrying potassium ferricyanide on nylon non-woven fabric 39, potassium ferricyanide crystals on the fabric became much finer and more soluble in liquids by hot air-drying nylon non-woven fabric impregnated with a potassium ferricyanide solution than by drying the fabric at room temperature. The potassium ferricyanide crystal on the fabric became further finer when the nylon non-woven fabric impregnated with a potassium ferricyanide solution was dipped in an organic solvent having a great solubility in water, for example ethanol, and vacuum-dried. By carrying potassium ferricyanide in a finely pulverized form, even a highly viscous sample such as blood completed the reaction within one minute with an improved reproducibility. Since the enzyme is poorly resistant to heat, etc., it was dried at room temperature after dipped in the above organic solvent. Also, when both the enzyme and oxidizing dye are carried on one piece of porous substrate, the dye and enzyme could be carried in a very soluble form by dipping the body in

0136361

ethanol and vacuum-drying. Further, the enzyme may be immobilized by crosslinking with glutaraldehyde after dipping, and it could be stored stably for a long time by such immobilization.

Example 6

In Example 5, a porous membrane such as nylon non-woven fabric was used as a porous substrate, but in addition to this, inorganic carriers such as SiO_2 also may be used in the form of a porous substrate produced by press-molding. When SiO_2 was pressure-molded into a size of 7mm (diameter) x 1mm (thickness) by 5 t/cm² pressure, impregnated with an aqueous solution containing glucose oxidase and potassium ferricyanide and then dried, penetration of blood into this molded SiO_2 was a little slower than in the nylon non-woven fabric. Since, however, the porous membrane of polycarbonate also can be produced at the same time by pressure-molding, the filter layer and reaction layer could integrally be molded to simplify their production. Further, it was also possible to finely pulverize glucose oxidase and potassium ferricyanide and after mixing and adding a small amount of SiO_2 , to pressure-mold the mixture. In this case, since the glucose oxidase and potassium ferricyanide rapidly dissolve in blood to form a uniform mixture, the reaction became very fast.

Example 7

In Example 5, blood was filtered using a filter layer treated with a surface active agent. In this example

0136362

however, this treated filter layer was further impregnated with 10mg/c.c. of a sodium fluoride (anticoagulant) solution and dried, and the procedure of Example 5 was repeated but using the filter layer thus obtained. As a result, blood could be filtered in only ten seconds without coagulation, and besides measurement was completed in as short a time as only 50 seconds after addition of blood. Thus, this method made a great contribution to acceleration of measurement.

As the anticoagulant, sodium fluoride is suitable because it is stable and simple in handling. But, heparin, sodium citrate, ethylenediamine tetraacetic acid, etc. were also useful to carry out blood filtration rapidly.

As the dye, potassium ferricyanide used in the foregoing examples is suitable because it reacts stably, but p-benzoquinone is suitable for acceleration because it is fast in reaction rate. Further, 2,6-dichlorophenol-indophenol, methylene blue, phenazine methosulfate, potassium β -naphthoquinone-4-sulfonate, etc. may also be used.

The sensors in the foregoing examples can be applied to not only glucose but also systems in which oxidoreductase takes part such as alcohol sensors, cholesterol sensors and the like. Glucose oxidase was used as the oxidoreductase, but other enzymes such as alcohol oxidase, xanthine oxidase, cholesterol oxidase, etc. may also be used.

0136362

Possibility of application to industry:

The bio-sensor of the present invention makes it possible to measure the particular component in various biological samples with rapidity, high precision and simplicity, so that its utility value in clinical inspection is very large.

0136362

WHAT IS CLAIMED IS:

1. In a bio-sensor for measuring the substrate concentration of a liquid sample by putting an electrode system comprising at least a working electrode and a counter electrode on an insulating substrate plate, bringing an enzyme, electron acceptor and said liquid sample to reaction, and detecting an electrochemical change caused by said reaction on said electrode system, a bio-sensor characterized in that the substrate concentration of said liquid sample is measured by covering the exposed surface of said electrode system with a porous substrate containing oxidoreductase and electrochemically detecting the electron acceptor reduced by said reaction on said electrode system.

2. A bio-sensor as described in Claim 1 characterized in that said porous substrate carried said oxidoreductase and electron acceptor.

3. A bio-sensor as described in Claim 1 characterized in that said working electrode comprises platinum and said counter electrode comprises platinum or silver/silver chloride.

4. A bio-sensor as described in Claim 1 characterized in that said electrode system is composed of a working electrode, a counter electrode and a reference electrode.

5. A bio-sensor as described in Claim 1 characterized in that said porous substrate is a hydrophilic

0136362

porous membrane.

6. A bio-sensor as described in Claim 1 characterized in that said electron acceptor is oxygen.

7. A bio-sensor as described in claim 1 characterized in that said enzyme is one member selected from the group consisting of glucose oxidase, alcohol oxidase, xanthine oxidase and cholesterol oxidase.

8. A bio-sensor as described in Claim 1 characterized in that, as said electron acceptor, an oxidizing dye working in conjugation with said oxidoreductase is used.

9. A bio-sensor as described in Claim 8, wherein, as said oxidizing dye working in conjugation with the oxidoreductase, one member selected from the group consisting of potassium ferricyanide, p-benzoquinone, 2,6-dichlorophenolindophenol, methylene blue, phenazine methosulfate and potassium β -naphthoquinone-4-sulfonate is used.

10. A bio-sensor as described in Claim 8 characterized in that said oxidoreductase is glucose oxidase and said electron acceptor is potassium ferrocyanide.

11. A bio-sensor as described in Claim 5 characterized in that at least the oxidoreductase in a dry state is carried on said porous membrane.

12. A bio-sensor as described in Claim 5, wherein said porous membrane has a pore diameter of not more than

0136362

3 μm .

13. A bio-sensor as described in Claim 5 characterized in that said porous substrate is a one previously treated with a surface active agent.

14. A bio-sensor as described in Claim 5 characterized in that an anticoagulant is carried on said porous membrane.

FIG. 1

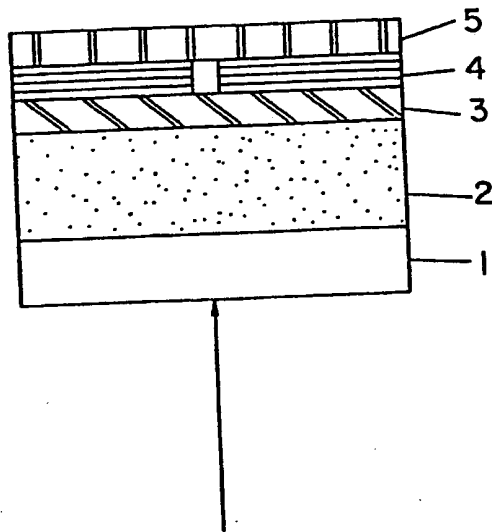

FIG. 2

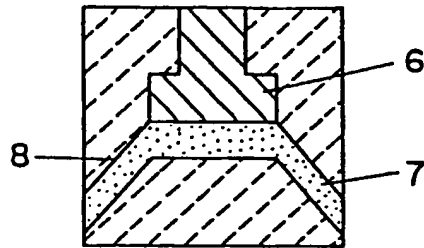

FIG. 3

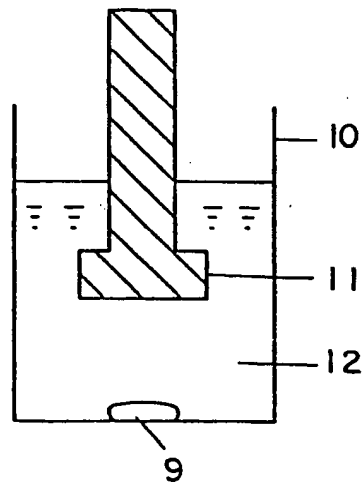

FIG. 4

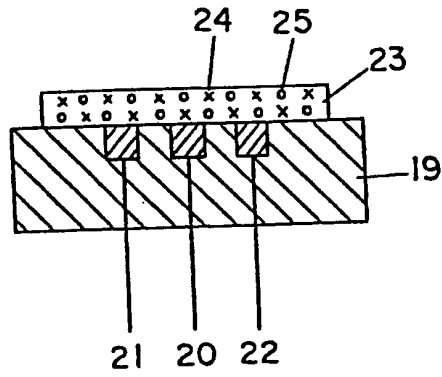

FIG. 5

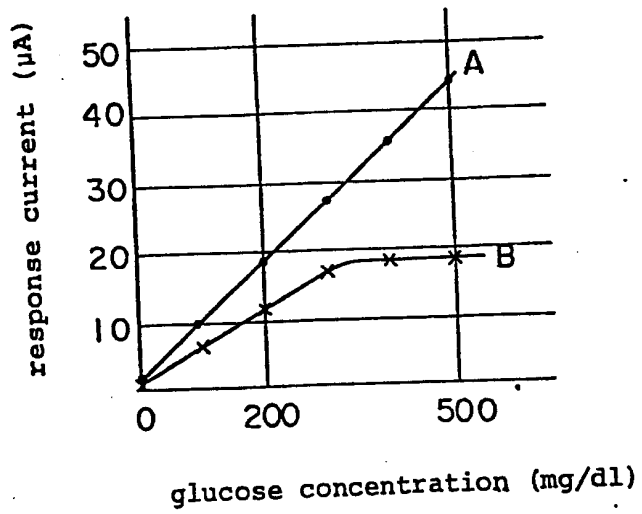

FIG. 6

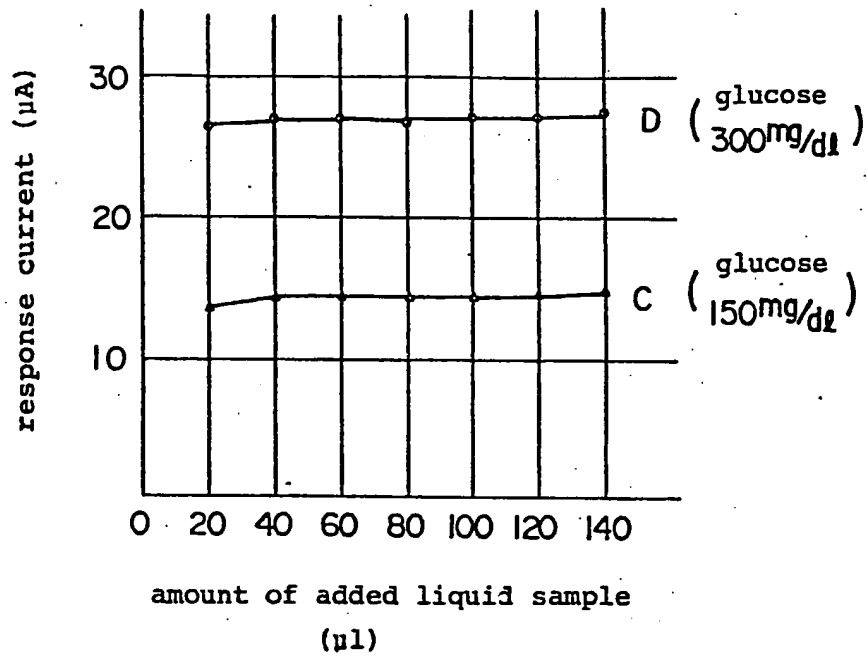

FIG. 7

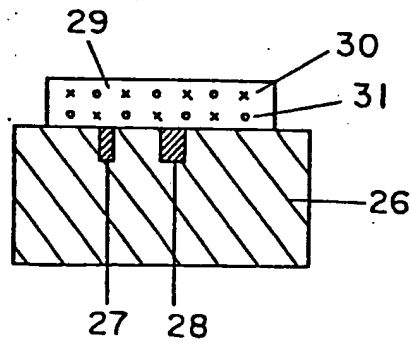

FIG. 8

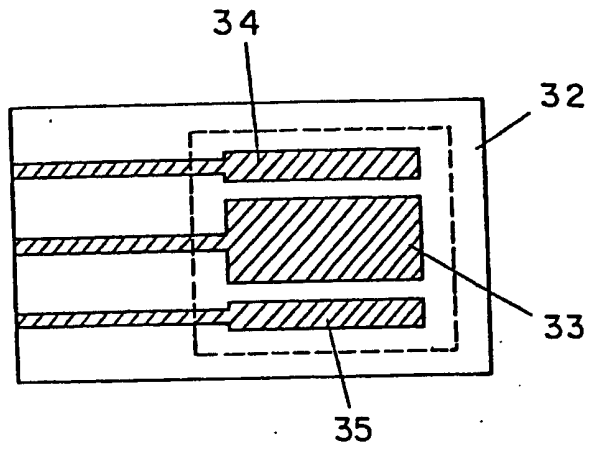
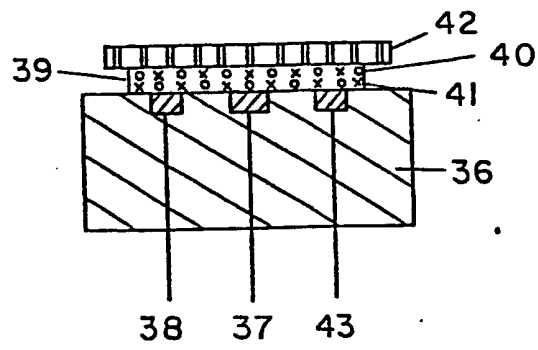

FIG. 9



List of symbols in the drawing:

- | | |
|----------------|----------------------------|
| 1 | Support |
| 2 | Reagent layer |
| 3 | Developing layer |
| 4 | Water-proof layer |
| 5, 42 | Filter layer |
| 6, 11 | Immobilized electrode |
| 7, 12 | Buffer solution |
| 8 | Conduit |
| 9 | Stirrer |
| 10 | Vessel |
| 20, 27, 33, 37 | Working electrode |
| 21, 28, 34, 38 | Counter electrode |
| 22, 35, 43 | Reference electrode |
| 23, 29, 39 | Non-woven fabric |
| 24, 30, 40 | Glucose oxidase |
| 25, 31, 41 | Potassium ferricyanide |
| 26, 32, 36 | Insulating substrate plate |

INTERNATIONAL SEARCH REPORT

0136362
PCT/JP84/00087

International Application No.

I. CLASSIFICATION OF SUBJECT MATTER (If several classification symbols apply, indicate all) ¹ According to International Patent Classification (IPC) or to both National Classification and IPC <p style="text-align: center; font-weight: bold;">G01N 27/30, G01N 27/46</p>																	
II. FIELDS SEARCHED <p style="text-align: center;">Minimum Documentation Searched⁴</p> <table border="1" style="width: 100%; border-collapse: collapse;"> <tr> <td style="width: 20%; padding: 5px;">Classification System</td> <td style="padding: 5px;">Classification Symbols</td> </tr> <tr> <td style="text-align: center; padding: 5px;">IPC</td> <td style="padding: 5px;">G01N 27/30, G01N 27/46, G01N 27/06</td> </tr> <tr> <td colspan="2" style="padding: 5px; text-align: center;">Documentation Searched other than Minimum Documentation to the Extent that such Documents are Included in the Fields Searched⁴</td> </tr> <tr> <td style="padding: 5px;">Jitsuyo Shinan Koho</td> <td style="text-align: right; padding: 5px;">1926 - 1984</td> </tr> <tr> <td style="padding: 5px;">Kokai Jitsuyo Shinan Koho</td> <td style="text-align: right; padding: 5px;">1971 - 1984</td> </tr> </table>			Classification System	Classification Symbols	IPC	G01N 27/30, G01N 27/46, G01N 27/06	Documentation Searched other than Minimum Documentation to the Extent that such Documents are Included in the Fields Searched ⁴		Jitsuyo Shinan Koho	1926 - 1984	Kokai Jitsuyo Shinan Koho	1971 - 1984					
Classification System	Classification Symbols																
IPC	G01N 27/30, G01N 27/46, G01N 27/06																
Documentation Searched other than Minimum Documentation to the Extent that such Documents are Included in the Fields Searched ⁴																	
Jitsuyo Shinan Koho	1926 - 1984																
Kokai Jitsuyo Shinan Koho	1971 - 1984																
III. DOCUMENTS CONSIDERED TO BE RELEVANT¹¹ <table border="1" style="width: 100%; border-collapse: collapse;"> <thead> <tr> <th style="width: 10%; padding: 5px;">Category⁷</th> <th style="width: 70%; padding: 5px;">Citation of Document, ¹⁶with indication, where appropriate, of the relevant passages ¹⁷</th> <th style="width: 20%; padding: 5px;">Relevant to Claim No. ¹⁸</th> </tr> </thead> <tbody> <tr> <td style="text-align: center; padding: 5px;">A</td> <td style="padding: 5px;">JP, A, 55-10584 (Matsushita Electric Industrial Co., Ltd.) 25 January 1980 (25. 01. 80)</td> <td style="text-align: center; padding: 5px;">1 - 12</td> </tr> <tr> <td style="text-align: center; padding: 5px;">A</td> <td style="padding: 5px;">JP, A, 55-98347 (Hitachi, Ltd.) 26 July 1980 (26. 07. 80)</td> <td style="text-align: center; padding: 5px;">1, 3, 5 - 7, 11 - 12</td> </tr> <tr> <td style="text-align: center; padding: 5px;">A</td> <td style="padding: 5px;">JP, A, 57-98853 (Matsushita Electric Industrial Co., Ltd.) 19 June 1982 (19. 06. 82)</td> <td style="text-align: center; padding: 5px;">1 - 12</td> </tr> <tr> <td style="text-align: center; padding: 5px;">A</td> <td style="padding: 5px;">JP, A, 57-106850 (Toshiba Corp.) 2 July 1982 (02. 07. 82)</td> <td style="text-align: center; padding: 5px;">1, 3, 5 - 7, 11 - 12</td> </tr> </tbody> </table>			Category ⁷	Citation of Document, ¹⁶ with indication, where appropriate, of the relevant passages ¹⁷	Relevant to Claim No. ¹⁸	A	JP, A, 55-10584 (Matsushita Electric Industrial Co., Ltd.) 25 January 1980 (25. 01. 80)	1 - 12	A	JP, A, 55-98347 (Hitachi, Ltd.) 26 July 1980 (26. 07. 80)	1, 3, 5 - 7, 11 - 12	A	JP, A, 57-98853 (Matsushita Electric Industrial Co., Ltd.) 19 June 1982 (19. 06. 82)	1 - 12	A	JP, A, 57-106850 (Toshiba Corp.) 2 July 1982 (02. 07. 82)	1, 3, 5 - 7, 11 - 12
Category ⁷	Citation of Document, ¹⁶ with indication, where appropriate, of the relevant passages ¹⁷	Relevant to Claim No. ¹⁸															
A	JP, A, 55-10584 (Matsushita Electric Industrial Co., Ltd.) 25 January 1980 (25. 01. 80)	1 - 12															
A	JP, A, 55-98347 (Hitachi, Ltd.) 26 July 1980 (26. 07. 80)	1, 3, 5 - 7, 11 - 12															
A	JP, A, 57-98853 (Matsushita Electric Industrial Co., Ltd.) 19 June 1982 (19. 06. 82)	1 - 12															
A	JP, A, 57-106850 (Toshiba Corp.) 2 July 1982 (02. 07. 82)	1, 3, 5 - 7, 11 - 12															
<table style="width: 100%; border: none;"> <tr> <td style="width: 50%; border: none; vertical-align: top;"> <p>¹⁵ Special categories of cited documents:</p> <p>"A" document defining the general state of the art which is not considered to be of particular relevance</p> <p>"E" earlier document but published on or after the international filing date</p> <p>"L" document which may throw doubts on priority claim(s) or which is cited to establish the publication date of another citation or other special reason (as specified)</p> <p>"O" document referring to an oral disclosure, use, exhibition or other means</p> <p>"P" document published prior to the international filing date but later than the priority date claimed</p> </td> <td style="width: 50%; border: none; vertical-align: top;"> <p>"T" later document published after the international filing date or priority date and not in conflict with the application but cited to understand the principle or theory underlying the invention</p> <p>"X" document of particular relevance; the claimed invention cannot be considered novel or cannot be considered to involve an inventive step</p> <p>"Y" document of particular relevance; the claimed invention cannot be considered to involve an inventive step when the document is combined with one or more other such documents, such combination being obvious to a person skilled in the art</p> <p>"g" document member of the same patent family</p> </td> </tr> </table>			<p>¹⁵ Special categories of cited documents:</p> <p>"A" document defining the general state of the art which is not considered to be of particular relevance</p> <p>"E" earlier document but published on or after the international filing date</p> <p>"L" document which may throw doubts on priority claim(s) or which is cited to establish the publication date of another citation or other special reason (as specified)</p> <p>"O" document referring to an oral disclosure, use, exhibition or other means</p> <p>"P" document published prior to the international filing date but later than the priority date claimed</p>	<p>"T" later document published after the international filing date or priority date and not in conflict with the application but cited to understand the principle or theory underlying the invention</p> <p>"X" document of particular relevance; the claimed invention cannot be considered novel or cannot be considered to involve an inventive step</p> <p>"Y" document of particular relevance; the claimed invention cannot be considered to involve an inventive step when the document is combined with one or more other such documents, such combination being obvious to a person skilled in the art</p> <p>"g" document member of the same patent family</p>													
<p>¹⁵ Special categories of cited documents:</p> <p>"A" document defining the general state of the art which is not considered to be of particular relevance</p> <p>"E" earlier document but published on or after the international filing date</p> <p>"L" document which may throw doubts on priority claim(s) or which is cited to establish the publication date of another citation or other special reason (as specified)</p> <p>"O" document referring to an oral disclosure, use, exhibition or other means</p> <p>"P" document published prior to the international filing date but later than the priority date claimed</p>	<p>"T" later document published after the international filing date or priority date and not in conflict with the application but cited to understand the principle or theory underlying the invention</p> <p>"X" document of particular relevance; the claimed invention cannot be considered novel or cannot be considered to involve an inventive step</p> <p>"Y" document of particular relevance; the claimed invention cannot be considered to involve an inventive step when the document is combined with one or more other such documents, such combination being obvious to a person skilled in the art</p> <p>"g" document member of the same patent family</p>																
IV. CERTIFICATION <table border="1" style="width: 100%; border-collapse: collapse;"> <tr> <td style="width: 50%; padding: 5px;">Date of the Actual Completion of the International Search¹ <p style="text-align: center;">May 22, 1984 (22. 05. 84)</p></td> <td style="width: 50%; padding: 5px;">Date of Mailing of this International Search Report² <p style="text-align: center;">May 28, 1984 (28. 05. 84)</p></td> </tr> <tr> <td style="padding: 5px;">International Searching Authority¹ <p style="text-align: center;">Japanese Patent Office</p></td> <td style="padding: 5px;">Signature of Authorized Officer²³</td> </tr> </table>			Date of the Actual Completion of the International Search ¹ <p style="text-align: center;">May 22, 1984 (22. 05. 84)</p>	Date of Mailing of this International Search Report ² <p style="text-align: center;">May 28, 1984 (28. 05. 84)</p>	International Searching Authority ¹ <p style="text-align: center;">Japanese Patent Office</p>	Signature of Authorized Officer ²³											
Date of the Actual Completion of the International Search ¹ <p style="text-align: center;">May 22, 1984 (22. 05. 84)</p>	Date of Mailing of this International Search Report ² <p style="text-align: center;">May 28, 1984 (28. 05. 84)</p>																
International Searching Authority ¹ <p style="text-align: center;">Japanese Patent Office</p>	Signature of Authorized Officer ²³																